



SAN JUAN BAUTISTA *The City of History*

Notice Inviting Bids

Fourth Street Speed Tables

The City of San Juan Bautista is inviting informal bids from responsible contractors to install up to four speed tables at locations identified on Exhibit A. The project includes installation of appropriate advance signage and lane striping per the attached scope of work.

The project includes installation of a minimum of three speed tables, with the potential for a fourth depending on the bid and the availability of funds.

The bid should identify the start and end dates of the installation with a start date no later than July 31, 2019. Construction must occur between the hours of 7AM and 5PM, excluding Sunday, and must allow at least one lane of through traffic (with proper traffic controls) at all times. The successful bidder will be required to attend a pre-construction meeting prior to initiating the project.

Using the attached bid form, the bid should indicate the not to exceed cost of constructing three speed tables, and the additional cost to install a fourth as a bid alternate.

Bids will be awarded in accordance with the City purchasing ordinance which allows for “informal” solicitation of bids for projects under \$175,000.

Bidders must be prepared to enter into the City’s standard contract (attached) and provide evidence of liability and workers compensation insurance. The successful bidder must possess a Class A contractor’s license and a City business license. Prevailing wages will be enforced on this project. Contractor must register with the Department of Industrial Relations (DIR) and provide all required reports and documentation.

Bids must be submitted by 4pm, Thursday, June 27, 2019 to:

City Clerk

311 Second Street

San Juan Bautista, CA 95045

Inquiries regarding this project may be addressed to Interim City Manager, citymanager@san-juan-bautista.ca.us

City of San Juan Bautista
Fourth Street Speed Tables

Scope of Work

Speed Tables – Construct speed tables using $\frac{1}{2}$ " maximum aggregate asphalt concrete. Compact to minimum 95% relative compaction. Height of speed table shall not vary more than $\frac{1}{4}$ " from designated value.

Markings – Pavement markings shall be thermoplastic.

Signs – Signs shall have a retroreflective surface on a 36" x 36" aluminum base sheet and conform to applicable portions of Caltrans Standard Plans, Caltrans Standard Specifications and the California Manual of Uniform Traffic Control Devices (CAMUTCD). Signs shall be mounted on 4" x 4" wood poles with a minimum embedment depth of 3.5'. The invert of the sign shall be a minimum of 84" above adjacent grade.

Traffic Control - Maintain a minimum of one traffic lane at all times during construction. Utilize flaggers as necessary to insure safe passage of traffic. During non-working hours provide for two lanes of traffic. Depressions in the pavement greater than one-inch in depth shall be covered with steel plate or backfilled with cutback asphalt concrete.

Traffic Safety – During the period between construction of the speed tables and final placement of all pavement markings, place barricades at the edge of the traveled way in front of the leading edge of the speed table with temporary signage indicating HUMP and other signage as required to provide adequate warning of the new construction.

Figure 3B-31. Advance Warning Markings for Speed Humps

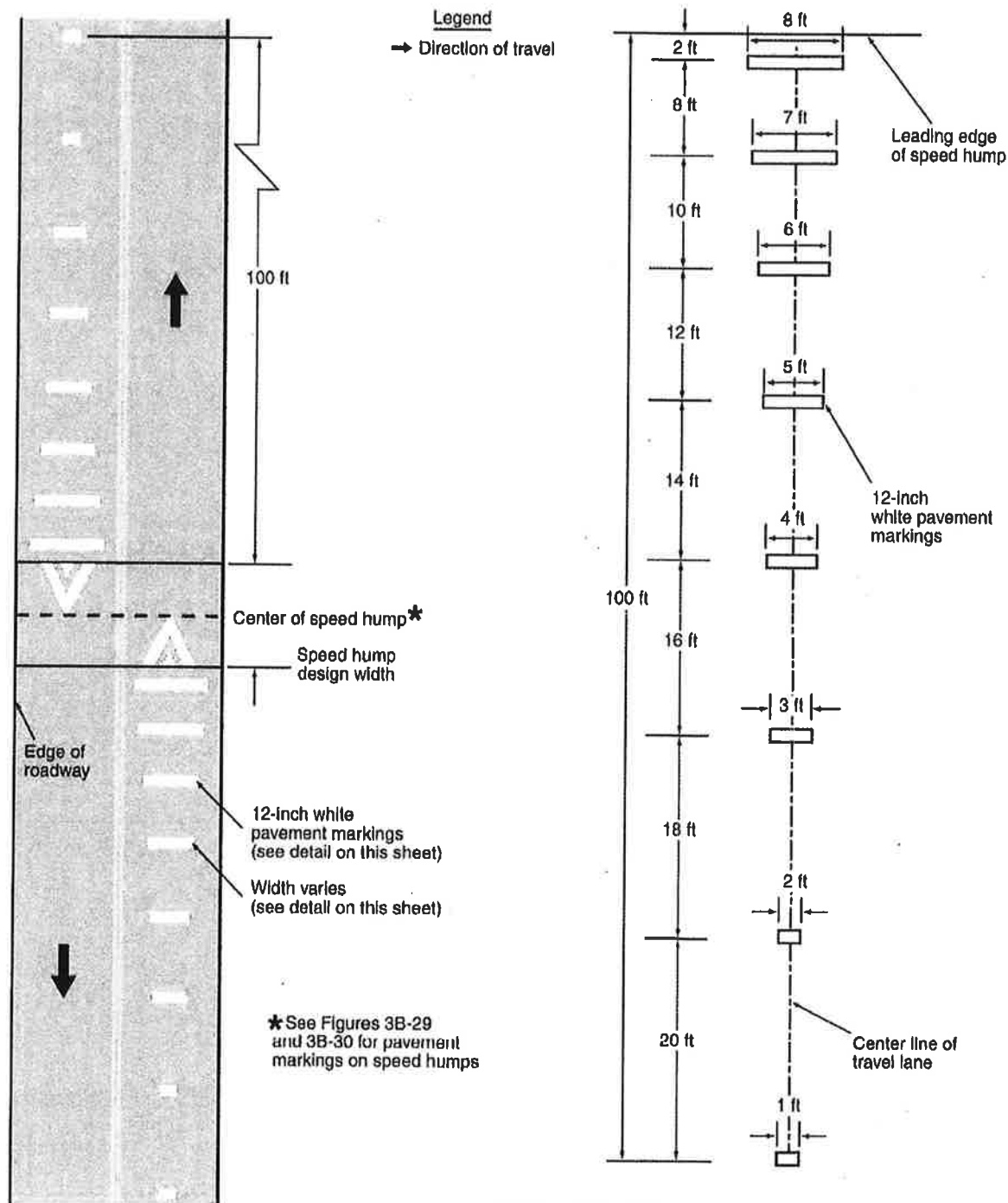

DETAIL—SPEED HUMP ADVANCE WARNING MARKINGS

Figure 3B-30. Pavement Markings for Speed Tables or Speed Humps with Crosswalks

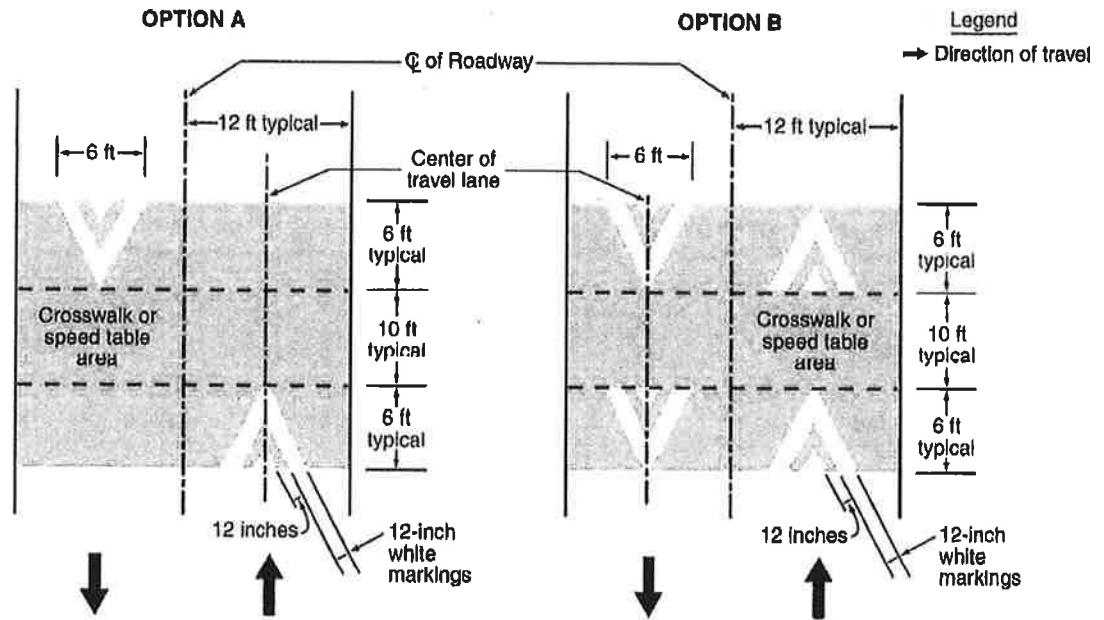

Note: Optional crosswalk lines are not shown in this figure

J:\DESIGN\19.100 - SHIL 4th Street Speed Tables\2019-06-04_05_SUBMITTAL\02_4TH_STREET_SPEEDS.dwg Plotted on: 06-06-19 11:37am



FOURTH STREET SPEED TABLES

LOCATE W17-1 "SPEED HUMP" SIGNS 10'-15' IN FRONT OF LEADING EDGE OF SPEED TABLE. EXACT LOCATION TO BE DETERMINED IN FIELD.

PREPARED BY:



CSG Consultants, Inc.
 550 Pilgrim Drive
 Foster City, CA 94404
 Phone (650) 522-2500
 Fax (650) 522-2599

CITY OF SAN JUAN BATISTA
 312 SECOND ST. P.O. BOX 1420
 SAN JUAN BATISTA, CA 94045

DATE: 06/06/2019	JOB NO. 19.100
DRAWN BY: EB	SHEET 1 OF 1

J:\DESIGN\19.100 - SHB_4th Street Speed Tables\2019-06-04_65_SUBMITTAL\01_SPEED TABLE.dwg Plotted on: 06-06-19 12:03pm

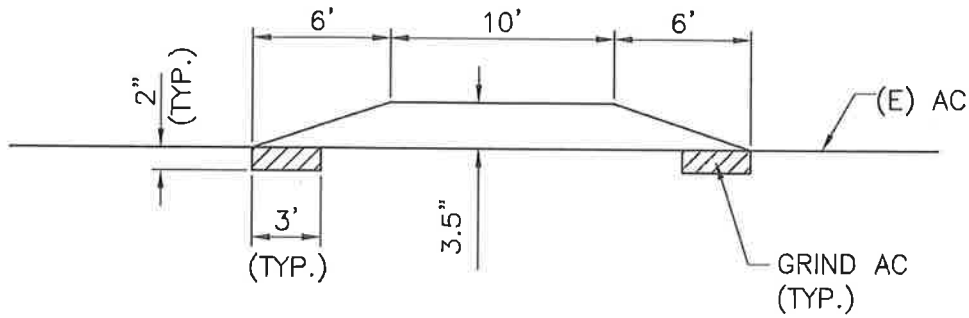

PROFILE
N.T.S.

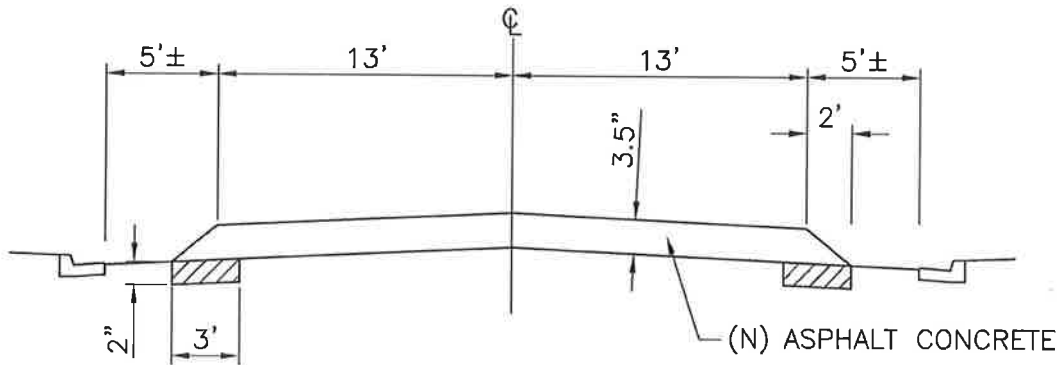

CROSS-SECTION
N.T.S.

FOR PAVEMENT MARKINGS ON SPEED TABLE - SEE FIGURE 3B-30, OPTION B OF CAMUTCD. FOR ADVANCE WARNING MARKINGS, SEE FIGURE 3B-31 OF CAMUTCD.

SPEED TABLE ON FOURTH STREET

PREPARED BY:



CSG Consultants, Inc.
550 Pilgrim Drive
Foster City, CA 94404
Phone (650) 522-2500
Fax (650) 522-2599

CITY OF SAN JUAN BATISTA
312 SECOND ST. P.O. BOX 1420
SAN JUAN BATISTA, CA 94045

DATE: 06/04/2019

JOB NO. 19.100

DRAWN BY: EB

SHEET 1 OF 1

City of San Juan Bautista
 Fourth Street Speed Tables

BID SHEET

BASE BID

BID ITEM	DESCRIPTION	QUANTITY	UNIT	UNIT COST	TOTAL COST
1	Construct Speed Table	3	EA		
2	New Roadside Signs	8	EA		
3	Pavement Markings (per Speed Table)	3	EA		
TOTAL BASE BID					

Note: Quantities may be reduced depending on available funds.

ALTERNATE BID

BID ITEM	DESCRIPTION	QUANTITY	UNIT	UNIT COST	TOTAL COST
A-1	Construct Speed Table	1	EA		
A-2	New Roadside Signs	2	EA		
A-3	Pavement Markings (per Speed Table)	1	EA		
TOTAL ALTERNATE BID					

TOTAL BASE + ALTERNATE _____